

# PhaseCam<sup>®</sup> 4030

4D

## High Performance Dynamic Twyman Green Interferometer

### Instantaneous Acquisition

The PhaseCam<sup>®</sup> 4030 is a compact, lightweight dynamic laser interferometer with simple, manual controls for measurement of optics and optical systems. The industry standard for measuring large, focal optical systems such as concave telescope mirrors and lens systems, the PhaseCam is equally well suited for testing small aperture afocal components such as flat mirrors and collimators.

The PhaseCam 4030 incorporates Dynamic Interferometry<sup>®</sup> technology, using a single camera, high-speed optical phase sensor that makes wavefront measurements in less than 30 microseconds—over 5000 times faster than a temporal phase shifting interferometer. Because acquisition time is so short, the PhaseCam can be used under almost any conditions, even for measuring moving parts, without vibration isolation. Vibration immunity makes the PhaseCam ideal for use on the production floor, in clean rooms and in environmental test chambers. It can even measure moving parts such as deformable or scanning mirrors, spinning disks, or vibrating membranes.

### Complete Measurement System

The PhaseCam 4030 is a turnkey instrument that includes the interferometer, 4Sight<sup>™</sup> Focus advanced wavefront analysis software and a high-speed computer system. Samples with any reflectivity from 1% to 100% can be measured with a simple adjustment. Its stabilized HeNe laser (632.8 nm) provides excellent coherence length and wavelength stability.

### Industry Leading Analysis, Standard

4Sight Focus wavefront acquisition and analysis software utilizes a user-friendly interface with unmatched simplicity, analysis features and graphical displays.

The 4Sight Focus 64-bit acquisition engine produces rapid analysis and display of single, averaged or burst measurements. Continuous data acquisition and real-time Zernike bar plots provide real-time visual feedback for simplifying optical system or beam train alignment.

The user-friendly interface makes data comparison, manipulation, masking, reference subtraction, filtering and terms removal simple to perform. Zernike, Seidel, geometric and diffraction analyses are standard. Comprehensive data sharing capabilities let you read, write, and save most file types, including Zemax, MatLab, Vision, MetroPro, HDF5 and CodeV.

### FEATURES

- Vibration Insensitive Dynamic Operation
- 30  $\mu$ sec Data Acquisition Time
- 4MP Camera
- Outstanding Data Analysis and Visualization Software

### APPLICATIONS

- Meter-Class Telescope Optics
- Quality Verification of Optical Components
- Vacuum and Environmental Chamber Testing
- Production Floor Quality Control
- Optical Testing of Moving Parts



PhaseCam Model 4030

# PhaseCam<sup>®</sup> 4030

## Specifications

Configuration	Model 4030
Description	Vibration insensitive dynamic Twyman-Green interferometer
Acquisition Mode	Single camera, high-speed optical phase sensor
Laser Source	Stabilized HeNe @ 632.8 nm
Typical Laser Power	1.0 mW
Maximum Cavity Length	> 100 m
Beam Diameter	7.0 mm collimated FWHM
Divergers	Range of lenses from f/1 to f/32
Polarization	Circular
Focus Range	±12.5 mm, optical magnification dependent
Pupil Magnification	1X fixed, 10X digital zoom
Fringe Contrast	User-adjustable for reflectivity from 1–100%
Camera	4MP, 12-bit standard
Data Array	User selectable full, half, quarter data arrays
Operating System	Windows <sup>®</sup> 10
System Software	4Sight™ Focus Analysis Software
	Instantaneous phase shifting data acquisition
	Reference generation, subtraction, data averaging, masking
	2D and 3D surface maps
	Zernike / Seidel / Slope / Geometric / Fourier Analysis
	Fiducial-aided data set mapping
	HDF5 data format standard, others supported
	Analysis of multiple sub-apertures
	Upgrades free during warranty period
Physical Envelope	65.4 × 21.7 × 13.8 cm (25.8 × 8.6 × 5.4 in)
Weight	13.6 kg (30.0 lbs)
Power consumption	< 750 Watts with computer
Temperature Range	Operational: 16–27° C (60–80° F), non-condensing Storage: -1–38° C (30–100° F), non-condensing

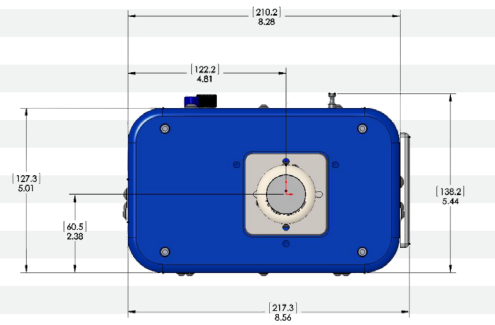
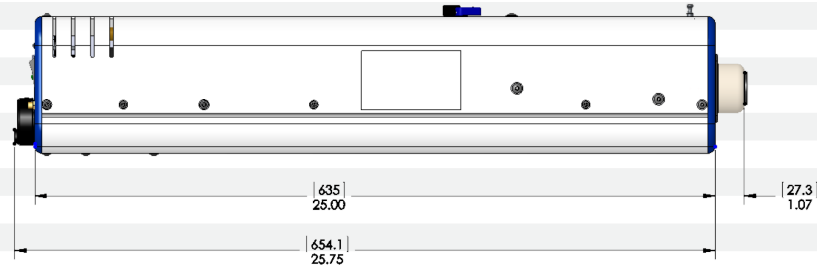

### System Performance

Acquisition Rate	> 10 frames/sec live video; 4 interferograms/frame > 20 frames/sec max data acquisition with post processing
Minimum Exposure	30 usec
Sample Reflectivity	1 to 100%
RMS Repeatability	< 0.001 wave*
RMS Precision	< 0.002 wave**

**Warranty** One Year, limited, on-site system installation and operator training

\* One sigma for RMS of 10 data sets of calibration mirror, each data set being an average of 16 measurements.

\*\* Average RMS of the pixel by pixel difference of 10 data sets between measured surface and the calibrated surface. Each data set is an average of 16 measurements. Calibrated surface is the average of all 160 measurements.

Patent 7,230,717. Other patents may apply.

PhaseCam and Dynamic Interferometry are registered trademarks of 4D Technology Corporation.

MetroPro IDL, MatLab, Opticode, Vision, HDF5, CodeV and Windows are registered trademarks of their respective owners.

All specifications subject to change without notice.

# 4D Technology

An Onto Innovation Business

2021.03.23 ■ ©4D Technology Corporation

